

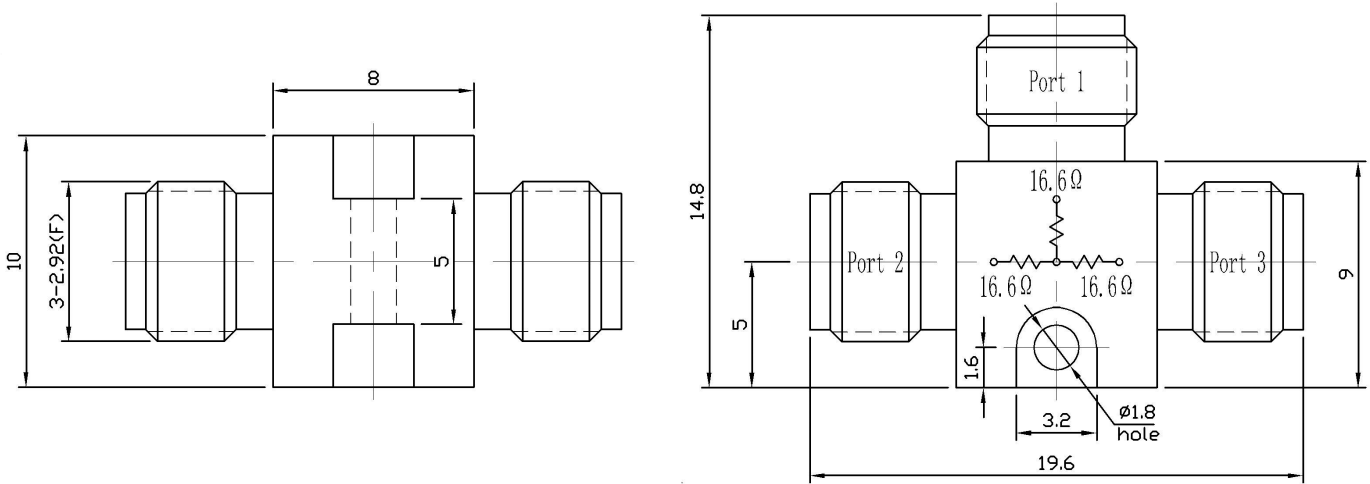

2.92mm(K,SK) 2 Way Resistive Power Divider, RPD40F2-A DC-40GHz, 5W, JP-Grade

Dimensions(mm) Tolerance±1%



Electrical & Environmental

Frequency Range	DC-40GHz	Impedance	50 Ohm
Input Port VSWR	1.38 max (26.5-40GHz); 1.26 max (DC-26.5GHz)	Output Port VSWR	1.38 max (26.5-40GHz); 1.26 max (DC-26.5GHz)
Insertion Loss	7.8dB max (26.5-40GHz); 6.8dB max (DC-26.5GHz)		
Amplitude Balance	≤±0.7dB (26.5-40GHz); ≤±0.5dB (DC-26.5GHz)	Phase Balance	≤±7° (26.5-40GHz); ≤±5° (DC-26.5GHz)
Input Avg Power	5 Watts max @25°C (Derate linearly to 0.5 Watt at 100°C)		
Operating Temp	-55°C~100°C		

Mechanical & Product Information

Product Number	RPD40F2-A, JP-Grade	Way	2
Connector	2.92mm(K,SK) Female	Connector Body	Passivated stainless steel
Center Contact	1.27um Gold plated beryllium copper		
Housing	Passivated stainless steel		
Dimensions	19.6×14.8×10mm	Net Weight	About 7.5g



2.92mm(K,SK) 2 Way Resistive Power Divider, RPD40F2-A DC-40GHz, 5W, JP-Grade

Typical Test Data

Port 1 and Port 2

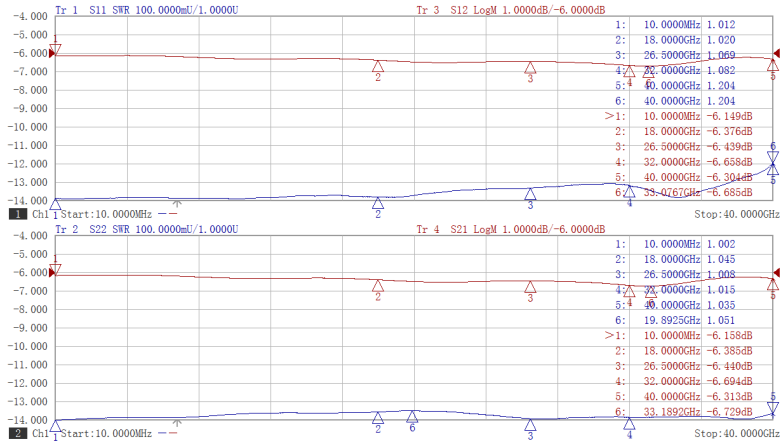

Port 1 and Port 3

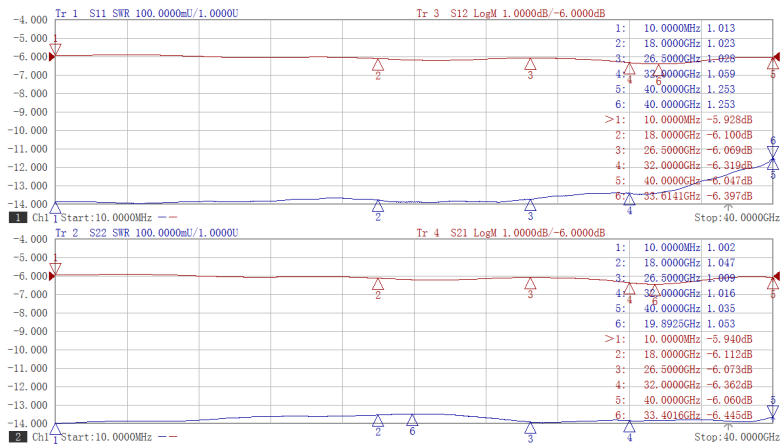

Port 2 and Port 3

