

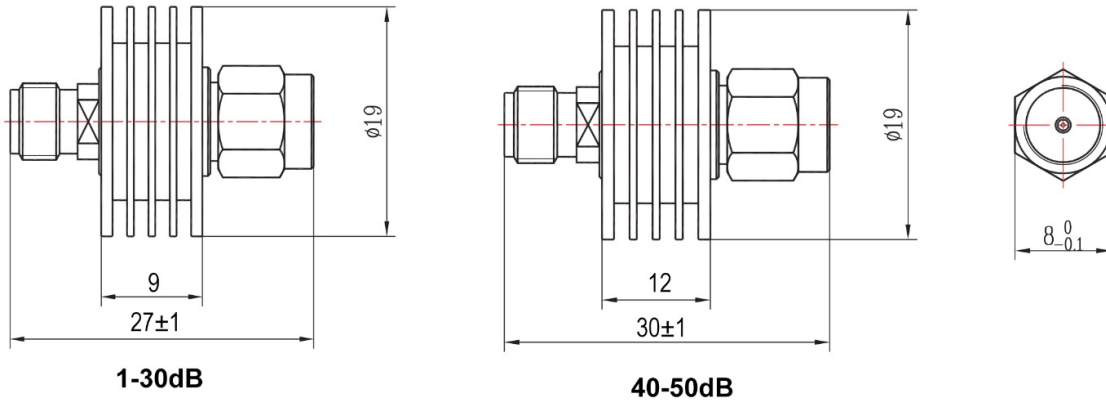

## SMA Coaxial Fixed Attenuator, R6S5-XX DC-6GHz, 5W, 1-60dB, Bidirectional, Round

### Dimensions(mm) Tolerance±1%



### Electrical & Environmental

<b>Frequency Range</b>	DC-6GHz , 50Ohms
<b>VSWR</b>	1.25 Max
<b>Input Avg Power</b>	5W @25°C
<b>Peak Power</b>	500W (5μsec pulse width, 0.5% duty cycle)
<b>Temp Coefficient</b>	<0.0004 dB/dB/°C
<b>Direction</b>	Bidirectional, SMA male to SMA female
<b>Attenuation</b>	1-60dB
<b>Operating Temp</b>	-55°C~-+125°C

### Product Selection, Customizable

RFTOP P/N	ATTEN	Accuracy
R6S5-3	3 dB	±0.5 dB
R6S5-5	5 dB	±0.5 dB
R6S5-6	6 dB	±0.5 dB
R6S5-10	10 dB	±0.5 dB
R6S5-15	15 dB	±0.6 dB
R6S5-20	20 dB	±0.6 dB
R6S5-30	30 dB	±0.8 dB
R6S5-40	40 dB	±1.0 dB

### Mechanical & Product Information

<b>Product Number</b>	R6S5-XX
<b>Product Type</b>	Coaxial Fixed Attenuator, P-Grade
<b>Connector</b>	SMA male, SMA female
<b>Connector Body</b>	Passivated stainless steel
<b>Center Contact</b>	Gold plated brass, Gold plated beryllium copper
<b>Heat Sink</b>	Black anodized aluminum
<b>Net Weight</b>	About 10.0g

**Notes:** Pay attention to input/output. To ensure longevity and performance, do not use at full power for a long time. Peak power, pulse width, and duty cycle need to meet the requirements. Input high power, require heat dissipation, maintain temperature within 80°C. Reference Curve, derate linearly to 0.5W at 100°C.

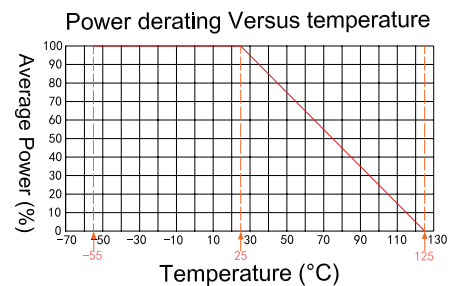

1. Customized connectors, dimensions, directionality, PIM, dB values.

2. Refer to the RFTOP attenuator selection and usage guide.



# SMA Coaxial Fixed Attenuator, R6S5-XX

## DC-6GHz, 5W, 1-60dB, Bidirectional, Round

### Typical Test Data

