

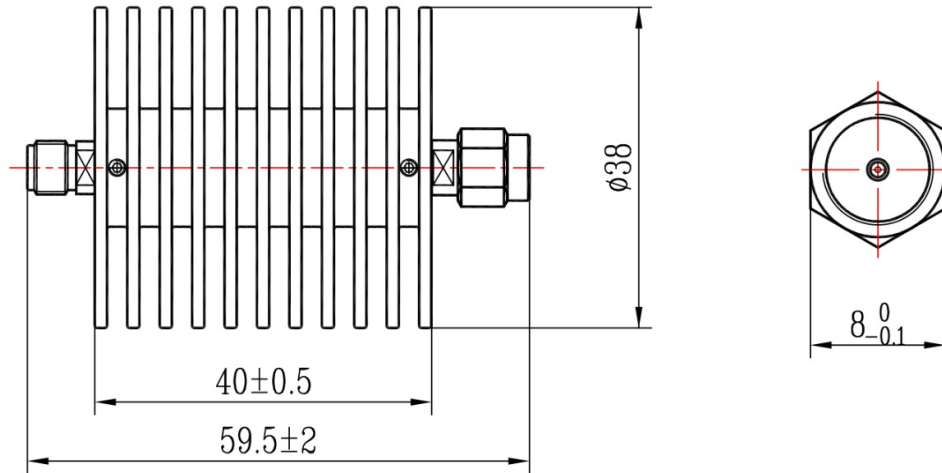

SMA Coaxial Fixed Attenuator, R6S20-XX
DC-6GHz, 20W, 1-40dB, Unidirectional, Round

Dimensions(mm) Tolerance±1%



Electrical & Environmental

Frequency Range	DC-6GHz , 50Ohms
VSWR	1.2 Max
Input Avg Power	20W @25°C
Peak Power	500W (5μsec pulse width, 1% duty cycle)
Temp Coefficient	<0.0004 dB/dB/°C
Direction	Unidirectional, SMA male input to SMA female output
Attenuation	1-40dB
Operating Temp	-55°C~+125°C

Product Selection, Customizable		
RFTOP P/N	ATTEN	Accuracy
R6S20-3	3 dB	±0.5 dB
R6S20-6	6 dB	±0.5 dB
R6S20-10	10 dB	±0.5 dB
R6S20-20	20 dB	±0.6 dB
R6S20-30	30 dB	±0.8 dB
R6S20-40	40 dB	±0.8 dB

Notes: Pay attention to input/output. To ensure longevity and performance, do not use at full power for a long time. Peak power, pulse width, and duty cycle need to meet the requirements. Input high power, require heat dissipation, maintain temperature within 80°C. Reference Curve, derate linearly to 2W at 100°C.

Mechanical & Product Information

Product Number	R6S20-XX
Product Type	Coaxial Fixed Attenuator, P-Grade
Connector	SMA male, SMA female
Connector Body	Passivated stainless steel
Center Contact	Gold plated brass, Gold plated beryllium copper
Heat Sink	Black anodized aluminum

1. Customized connectors, dimensions, directionality, PIM, dB values.
2. Refer to the RFTOP attenuator selection and usage guide.

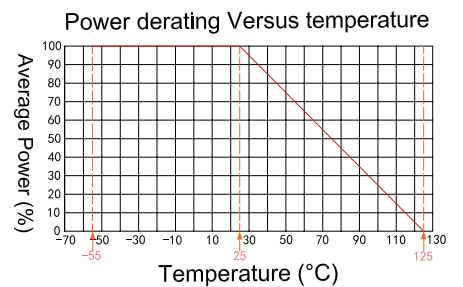



SMA Coaxial Fixed Attenuator, R6S20-XX

DC-6GHz, 20W, 1-40dB, Unidirectional, Round

Typical Test Data

