

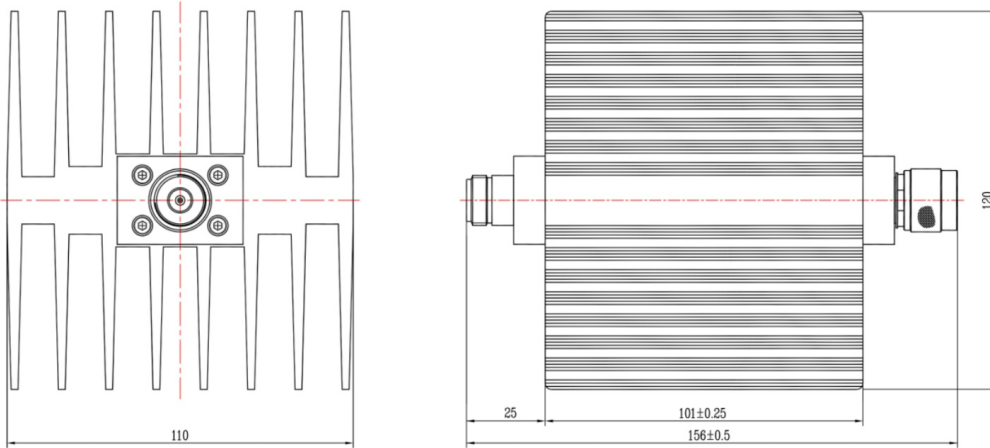

## N Coaxial Fixed Attenuator, R6N100UA-XX DC-6GHz, 100W, 6-60dB, Unidirectional, Rectangular

### Dimensions(mm) Tolerance±1%



### Electrical & Environmental

<b>Frequency Range</b>	DC-6GHz , 50Ohms
<b>VSWR</b>	1.25 Max
<b>Input Avg Power</b>	100W @25°C
<b>Peak Power</b>	1kW (5μsec pulse width, 5% duty cycle)
<b>Temp Coefficient</b>	<0.0004 dB/dB/°C
<b>Direction</b>	Unidirectional, N male input to N female output
<b>Attenuation</b>	6-60dB
<b>Operating Temp</b>	-55°C~+100°C

Product Selection, Customizable		
RFTOP P/N	Values	Accuracy
R6N100UA-6	6dB	±0.8dB
R6N100UA-10	10dB	±0.8dB
R6N100UA-20	20dB	±0.8dB
R6N100UA-30	30dB	±0.9dB
R6N100UA-40	40dB	±0.9dB
R6N100UA-50	50dB	±0.9dB
R6N100UA-60	60dB	±1.0dB

### Mechanical & Product Information

<b>Product Number</b>	R6N100UA-XX
<b>Product Type</b>	Coaxial Fixed Attenuator, P-Grade
<b>Connector</b>	N male, N female
<b>Connector Body</b>	Ternary alloy plated brass
<b>Center Contact</b>	Gold plated brass, Gold plated beryllium copper
<b>Heat Sink</b>	Black anodized aluminum
<b>Net Weight</b>	About 1.5kg

**Notes:** Pay attention to input/output. To ensure longevity and performance, do not use at full power for a long time. Peak power, pulse width, and duty cycle need to meet the requirements. Input high power, require heat dissipation, maintain temperature within 80°C. Reference Curve, derate linearly to 10W at 100°C.

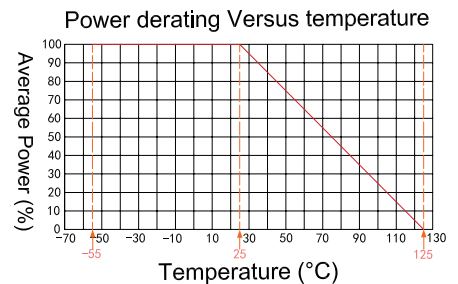

1. Customized connectors, dimensions, directionality, PIM, dB values.

2. Refer to the RFTOP attenuator selection and usage guide.



# N Coaxial Fixed Attenuator, R6N100UA-XX

## DC-6GHz, 100W, 6-60dB, Unidirectional, Rectangular

### Typical Test Data

