

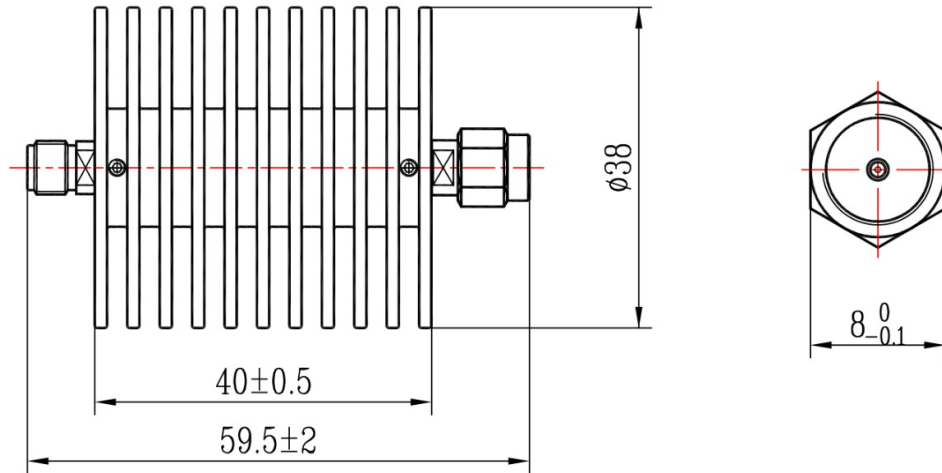

SMA Coaxial Fixed Attenuator, R18S25-XX DC-18GHz, 25W, 1-40dB, Unidirectional, Round

Dimensions(mm) Tolerance±1%



Electrical & Environmental

Frequency Range	DC-18GHz , 50Ohms
VSWR	1.35 Max
Input Avg Power	25W @25°C
Peak Power	500W (5μsec pulse width, 2.5% duty cycle)
Temp Coefficient	<0.0004 dB/dB/°C
Direction	Unidirectional, SMA male input to SMA female output
Attenuation	1-40dB
Operating Temp	-55°C~+125°C

Product Selection, Customizable

RFTOP P/N	ATTEN	Accuracy
R18S25-3	3 dB	±0.6 dB
R18S25-5	5 dB	±0.6 dB
R18S25-6	6 dB	±0.6 dB
R18S25-10	10 dB	±0.6 dB
R18S25-20	20 dB	±0.8 dB
R18S25-30	30 dB	±1.0 dB
R18S25-40	40 dB	±1.2 dB

Mechanical & Product Information

Product Number	R18S25-XX
Product Type	Coaxial Fixed Attenuator, P-Grade
Connector	SMA male, SMA female
Connector Body	Passivated stainless steel
Center Contact	Gold plated brass, Gold plated beryllium copper
Heat Sink	Black anodized aluminum
Net Weight	About 65.0g

Notes: Pay attention to input/output. To ensure longevity and performance, do not use at full power for a long time. Peak power, pulse width, and duty cycle need to meet the requirements. Input high power, require heat dissipation, maintain temperature within 60°C. Reference Curve, derate linearly to 3W at 100°C.

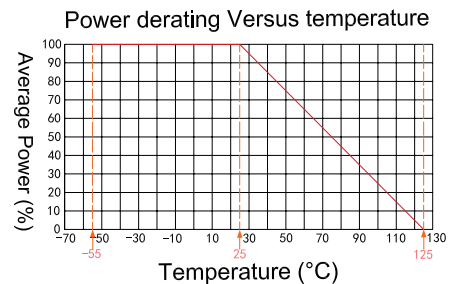

1. Customized connectors, dimensions, directionality, PIM, dB values.

2. Refer to the RFTOP attenuator selection and usage guide.



SMA Coaxial Fixed Attenuator, R18S25-XX

DC-18GHz, 25W, 1-40dB, Unidirectional, Round

Typical Test Data

