

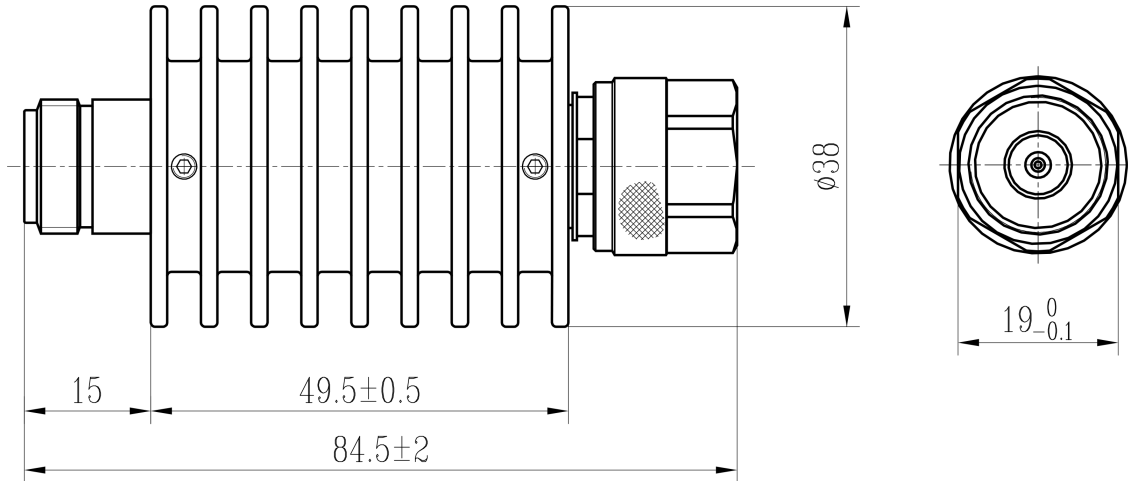

**N Coaxial Fixed Attenuator, R18N20-XX**  
**DC-18GHz, 20W, 1-60dB, Bidirectional, Round**

**Dimensions(mm) Tolerance±1%**



**Electrical & Environmental**

<b>Frequency Range</b>	DC-18GHz , 50Ohms
<b>VSWR</b>	1.45 Max
<b>Input Avg Power</b>	20W @25°C
<b>Peak Power</b>	800W (5μsec pulse width, 1.25% duty cycle)
<b>Temp Coefficient</b>	<0.0004 dB/dB/°C
<b>Direction</b>	Bidirectional, N male to N female
<b>Attenuation</b>	1-60dB
<b>Operating Temp</b>	-55°C~+100°C

Product Selection, Customizable		
RFTOP P/N	ATTEN	Accuracy
R18N20-3	3 dB	±0.6 dB
R18N20-6	6 dB	±0.6 dB
R18N20-10	10 dB	±0.6 dB
R18N20-20	20 dB	±0.8 dB
R18N20-30	30 dB	±1.0 dB
R18N20-40	40 dB	±1.2 dB
R18N20-50	50 dB	±1.4 dB
R18N20-60	60 dB	±1.4 dB

**Mechanical & Product Information**

<b>Product Number</b>	R18N20-XX
<b>Product Type</b>	Coaxial Fixed Attenuator, P-Grade
<b>Connector</b>	N male, N female
<b>Connector Body</b>	Passivated stainless steel
<b>Center Contact</b>	Gold plated brass, Gold plated beryllium copper
<b>Heat Sink</b>	Black anodized aluminum
<b>Net Weight</b>	About 120.0g

**Notes:** Pay attention to input/output. To ensure longevity and performance, do not use at full power for a long time. Peak power, pulse width, and duty cycle need to meet the requirements. Input high power, require heat dissipation, maintain temperature within 80°C. Reference Curve, derate linearly to 2W at 100°C.

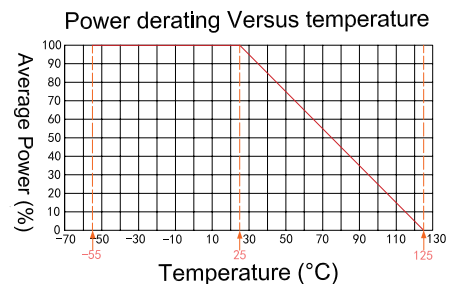

1. Customized connectors, dimensions, directionality, PIM, dB values.
2. Refer to the RFTOP attenuator selection and usage guide.



**N Coaxial Fixed Attenuator, R18N20-XX**  
**DC-18GHz, 20W, 1-60dB, Bidirectional, Round**

**Typical Test Data**

