

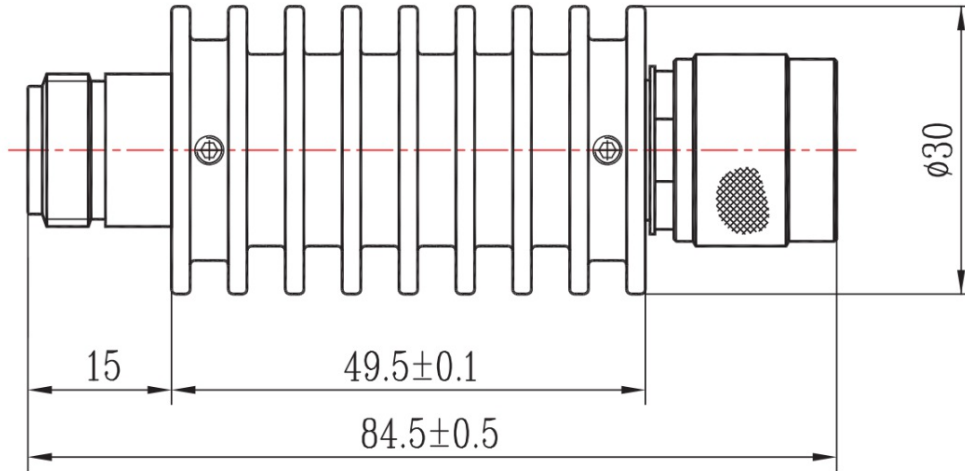

N Coaxial Fixed Attenuator, R18N15-XX
DC-18GHz, 15W, 1-40dB, Bidirectional, Round

Dimensions(mm) Tolerance±1%



Electrical & Environmental

Frequency Range	DC-18GHz , 50Ohms
VSWR	1.45 Max
Input Avg Power	15W @25°C
Peak Power	500W (5µsec pulse width, 1% duty cycle)
Temp Coefficient	<0.0004 dB/dB/°C
Direction	Bidirectional, N male to N female
Attenuation	1-40dB
Operating Temp	-55°C~+125°C

Product Selection, Customizable		
RFTOP P/N	ATTEN	Accuracy
R18N15-3	3 dB	±0.6 dB
R18N15-6	6 dB	±0.6 dB
R18N15-10	10 dB	±0.6 dB
R18N15-20	20 dB	±0.8 dB
R18N15-30	30 dB	±1.0 dB
R18N15-40	40 dB	±1.2 dB

Mechanical & Product Information

Product Number	R18N15-XX
Product Type	Coaxial Fixed Attenuator, P-Grade
Connector	N male, N female
Connector Body	Passivated stainless steel
Center Contact	Gold plated brass, Gold plated beryllium copper
Heat Sink	Black anodized aluminum
Net Weight	About 115.0g

Notes: Pay attention to input/output. To ensure longevity and performance, do not use at full power for a long time. Peak power, pulse width, and duty cycle need to meet the requirements. Input high power, require heat dissipation, maintain temperature within 80°C. Reference Curve, derate linearly to 2W at 100°C.

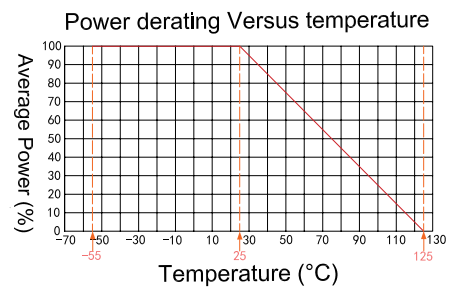

1. Customized connectors, dimensions, directionality, PIM, dB values.
2. Refer to the RFTOP attenuator selection and usage guide.



N Coaxial Fixed Attenuator, R18N15-XX
DC-18GHz, 15W, 1-40dB, Bidirectional, Round

Typical Test Data

