

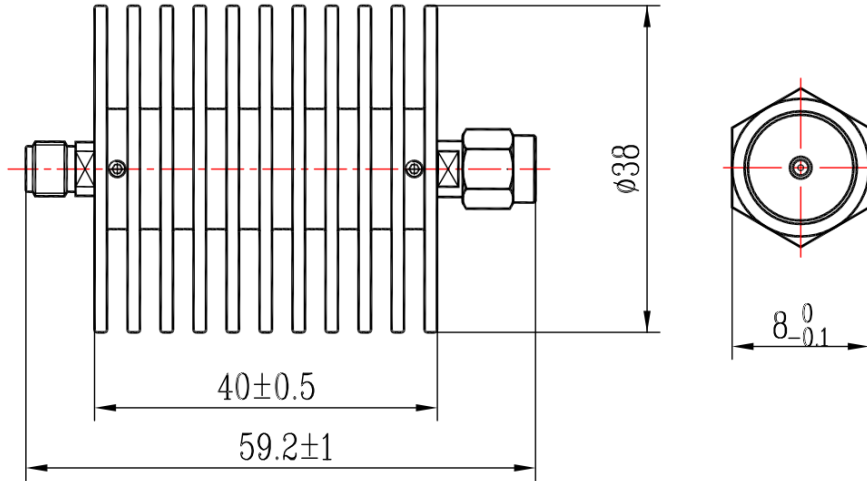

## SMA Coaxial Fixed Attenuator, R12S30U-XX DC-12.4GHz, 30W, 1-60dB, Unidirectional, Round

### Dimensions(mm) Tolerance±1%



### Electrical & Environmental

<b>Frequency Range</b>	DC-12.4GHz , 50Ohms
<b>VSWR</b>	1.25 Max
<b>Input Avg Power</b>	30W @25°C
<b>Peak Power</b>	500W (5µsec pulse width, 3% duty cycle)
<b>Temp Coefficient</b>	<0.0004 dB/dB/°C
<b>Direction</b>	Unidirectional, SMA male input to SMA female output
<b>Attenuation</b>	1-60dB
<b>Operating Temp</b>	-55°C~+125°C

Product Selection, Customizable		
RFTOP P/N	ATTEN	Accuracy
R12S30U-3	3 dB	±0.6 dB
R12S30U-6	6 dB	±0.6 dB
R12S30U-10	10 dB	±0.6 dB
R12S30U-20	20 dB	±0.7 dB
R12S30U-30	30 dB	±0.8 dB
R12S30U-40	40 dB	±0.9 dB
R12S30U-50	50 dB	±1.0 dB
R12S30U-60	60 dB	±1.1 dB

### Mechanical & Product Information

<b>Product Number</b>	R12S30U-XX
<b>Product Type</b>	Coaxial Fixed Attenuator, P-Grade
<b>Connector</b>	SMA male, SMA female
<b>Connector Body</b>	Passivated stainless steel
<b>Center Contact</b>	Gold plated brass, Gold plated beryllium copper
<b>Heat Sink</b>	Black anodized aluminum

**Notes:** Pay attention to input/output. To ensure longevity and performance, do not use at full power for a long time. Peak power, pulse width, and duty cycle need to meet the requirements. Input high power, require heat dissipation, maintain temperature within 80°C. Reference Curve, derate linearly to 3W at 100°C.

1. Customized connectors, dimensions, directionality, PIM, dB values.
2. Refer to the RFTOP attenuator selection and usage guide.

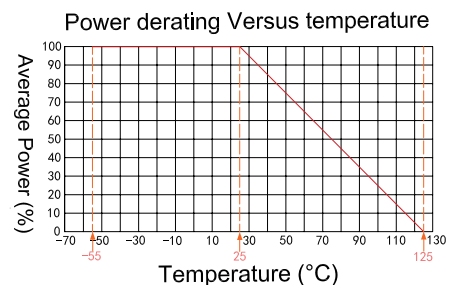



## SMA Coaxial Fixed Attenuator, R12S30U-XX DC-12.4GHz, 30W, 1-60dB, Unidirectional, Round

### Typical Test Data

