

WR19 Standard Gain Horn Antenna, 1.85mm Female, RWHAL19V-15 39.2-59.6GHz, 15dB Nominal Gain, FUGP500 Circular Flange, Right Angle

Dimensions(mm) Tolerance $\pm 1\%$

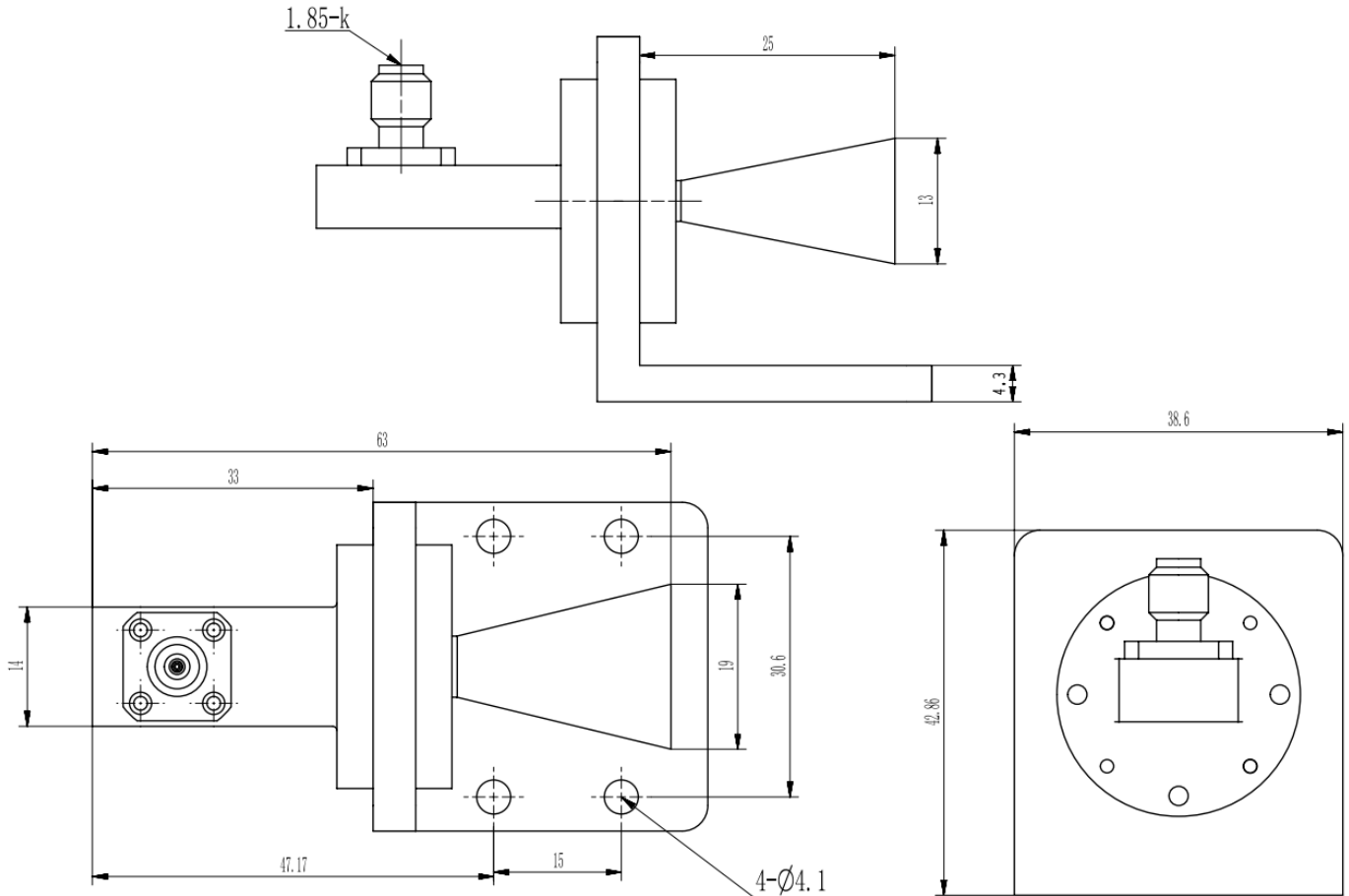

Electrical & Environmental

Frequency Range	39.2-59.6GHz	Impedance	50 Ohm
VSWR	1.3 Max		
Nominal Gain	15 dBi		

Mechanical & Product Information

Product Number	RWHAL19V-15, P-Grade, With bracket	Product Type	Standard Gain Horn Antenna
Connector	1.85mm Female, Right Angle	Connector Body	Passivated stainless steel
Waveguide	WR19(BJ500), FUGP500 Circular Flange	Waveguide Body	Copper, gold plated
Center Contact	Copper, gold plated		
Dimensions	63(L)*19(W)*13(H)mm	Net Weight	-



Microwave and Millimeter wave products
supplier

RFTOP® Technology Co., Ltd.
www.rftop.com service@rftop.com 86-755-88840350